

KAYCEE

Brand that set the standards



P
R
O
D
U
C
T
C
A
T
A
L
O
G
U
E



PRODUCT CATALOGUE



KAYCEE
Brand that set the standards

**COPPER RING TONGUE TERMINAL ENDS FOR
SOLDERLESS CRIMPING TO COPPER /
ALUMINUM CONDUCTORS.**

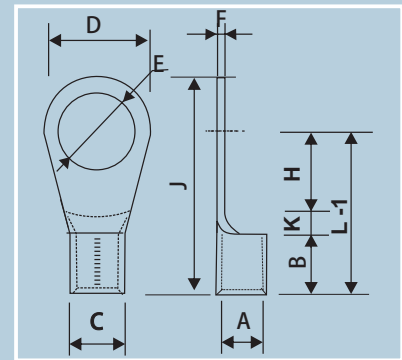

- Copper IS - 1897
- Electro Tinned finish

Item No.	AREA mm ²	E	A	C	D	F	B	K	H	L-1	J	KAYCEE CAT. No.
1	1.5	2.2	1.6	3.2	6	0.8	5	2	4.0	11.0	14.0	KC 7103
2	1.5	2.6	1.6	3.2	6.0	0.8	5	2	4.0	11.0	14.0	KC 7000
3	1.5	3.2	1.6	3.2	6.0	0.8	5	2	4.0	11.0	14.0	KC 7001
4	1.5	3.2	1.6	3.2	6.8	0.8	5	1	3.6	9.6	13.0	KC 7153
5	1.5	3.2	1.6	3.2	8	0.8	5	2	5.0	12.0	16.0	KC 7104
6	1.5	3.7	1.6	3.2	6.8	0.8	5	1	3.6	9.6	13.0	KC 7048
7	1.5	3.7	1.6	3.2	6.0	0.8	5	2	4.0	11.0	14.0	KC 7002
8	1.5	4.2	1.6	3.2	6.8	0.8	5	1	3.6	9.6	13.0	KC 7049
9	1.5	4.2	1.6	3.2	6.0	0.8	5	2	4.0	11.0	14.0	KC 7003
10	1.5	4.2	1.6	3.2	7.0	0.8	5	1	5.0	11.0	14.5	KC 7154
11	1.5	4.2	1.6	3.2	8.0	0.8	5	2	5.0	12.0	16.0	KC 7004
12	1.5	4.2	1.6	3.2	10	0.8	5	2	6.0	13.0	18.0	KC 7105
13	1.5	5.2	1.6	3.2	8.0	0.8	5	2	5.0	12.0	16.0	KC 7005
14	1.5	5.2	1.6	3.2	10.0	0.8	5	2	6.0	13.0	18.0	KC 7006
15	1.5	6.4	1.6	3.2	10.0	0.8	5	2	6.0	13.0	18.0	KC 7007
16	1.5	6.4	1.6	3.2	12.0	0.8	5	1	6.0	12.0	18.0	KC 7106
17	2.5	3.2	2.3	3.9	6.5	0.8	5	1	3.5	9.5	12.7	KC 7107
18	2.5	3.7	2.3	3.9	6.5	0.8	5	1	3.5	9.5	12.7	KC 7008
19	2.5	3.7	2.3	3.9	8.0	0.8	5	2	5.0	12.0	16.0	KC 7108
20	2.5	4.2	2.3	3.9	8.0	0.8	5	2	5.0	12.0	16.0	KC 7009
21	2.5	5.2	2.3	3.9	8.0	0.8	5	2	5.0	12.0	16.0	KC 7010
22	2.5	5.2	2.3	3.9	10.0	0.8	5	1	7.0	13.0	18.0	KC 7109
23	2.5	5.2	2.3	3.9	12.0	0.8	5	2	9.0	16.0	22.0	KC 7110
24	2.5	6.4	2.3	3.9	10.0	0.8	5	1	7.0	13.0	18.0	KC 7011
25	2.5	6.4	2.3	3.9	12.0	0.8	5	2	9.0	16.0	22.0	KC 7012
26	2.5	6.4	2.3	3.9	16	0.8	5	2	10.0	17.0	25.0	KC 7111
27	2.5	8.2	2.3	3.9	12.0	0.8	5	2	9.0	16.0	22.0	KC 7013
28	2.5	8.2	2.3	3.9	16.0	0.8	5	2	10.0	17.0	25.0	KC 7014
29	2.5	10.2	2.3	3.9	18.0	0.8	5	1	14.0	20.0	29.0	KC 7151
30	2.5	10.2	2.3	3.9	16	0.8	5	2	10.0	17.0	25.0	KC 7015
31	2.5	12.7	2.3	3.9	18	0.8	5	1	14.0	20.0	29.0	KC 7047
32	4-6	4.2	3.5	5.5	8.0	1.0	6	2	5.0	13.0	17.0	KC 7155
33	4-6	4.2	3.5	5.5	10	1.0	6	3	5.0	14.0	19.0	KC 7112
34	4-6	5.2	3.5	5.5	8.0	1.0	6	2	5.0	13.0	17.0	KC 7050
35	4-6	5.2	3.5	5.5	8.0	1.0	6	3	9.8	18.8	22.8	KC 7157
36	4-6	5.2	3.5	5.5	10.0	1.0	6	3	5.0	14.0	19.0	KC 7016
37	4-6	5.2	3.5	5.5	12	1.0	6	2	6.0	14.0	20.0	KC 7113
38	4-6	5.2	3.5	5.5	12	1.0	6	3	7.0	16.0	22.0	KC 7114
39	4-6	6.4	3.5	5.5	12	1.0	6	2	6	14	20	KC 7017
40	4-6	6.4	3.5	5.5	12	1.0	6	3	7	16	22	KC 7019
41	4-6	6.4	3.5	5.5	14	1.0	6	2	10.5	18.5	25.5	KC 7115
42	4-6	8.2	3.5	5.5	12	1.0	6	2	6	14	20	KC 7018
43	4-6	8.2	3.5	5.5	18	1.0	6	3	12.0	21.0	30.0	KC 7117
44	4-6	8.2	3.5	5.5	14	1.0	6	2	10.5	18.5	25.5	KC 7020
45	4-6	8.2	3.5	5.5	16	1.0	6	3	13	22	30	KC 7116
46	4-6	9.7	3.5	5.5	14	1.0	6	2	10.5	18.5	25.5	KC 7021

PRODUCT CATALOGUE



KAYCEE
Brand that set the standards

Item No.	AREA mm ²	E	A	C	D	F	B	K	H	L-1	J	KAYCEE CAT. No.
47	4-6	10.2	3.5	5.5	18	1.0	6	3	12	21	30	KC 7023
48	4-6	10.2	3.5	5.5	16	1.0	6	3	13.0	22.0	30.0	KC 7022
49	4-6	12.7	3.5	5.5	18	1.0	6	3	12	21	30	KC 7024
50	10	4.2	4.3	6.3	10	1.0	8	3	4	15	20	KC 7119
51	10	4.2	4.3	6.3	10	1.0	8	2	7.0	17.0	22.0	KC 7118
52	10	5.2	4.3	6.3	10	1.0	8	2	7	17	22	KC 7025
53	10	5.2	4.3	6.3	10	1.0	8	3	4	15	20	KC 7026
54	10	6.4	4.3	6.3	12	1.0	8	2	7	17	23	KC 7120
55	10	8.2	4.3	6.3	16	1.0	8	4	7	19	27	KC 7121
56	10	8.2	4.3	6.3	18	1.0	8	4	9.0	21.0	30.0	KC 7122
57	10	10.2	4.3	6.3	22	1.0	8	5	10	23	34	KC 7123
58	10	10.2	4.3	6.3	18	1.0	8	4	9.0	21.0	30.0	KC 7027
59	10	12.7	4.3	6.3	22	1.0	8	5	10	23	34	KC 7028
60	16	5.2	5.6	8.0	10	1.2	10	3	6	19	24	KC 7124
61	16	5.2	5.6	8.0	12	1.2	10	4	6	20	26	KC 7125
62	16	6.4	5.6	8.0	12	1.2	10	4	6	20	26	KC 7029
63	16	6.4	5.6	8.0	16	1.2	10	4	8	22	30	KC 7126
64	16	8.2	5.6	8.0	16	1.2	10	4	8	22	30	KC 7030
65	16	8.2	5.6	8.0	18	1.2	10	4	10	24	33	KC 7127
66	16	9.7	5.6	8.0	16	1.2	10	4	8	22	30	KC 7031
67	16	10.2	5.6	8.0	22	1.2	10	6	8	24	35	KC 7128
68	16	10.2	5.6	8.0	18	1.2	10	4	10	24	33	KC 7032
69	16	12.7	5.6	8.0	22	1.2	10	6	8	24	35	KC 7033
70	25	6.4	7.5	11.1	16	1.8	11	4	10	25	33	KC 7130
71	25	6.4	7.5	11.1	12	1.8	11	4	10	25	31	KC 7156
72	25	6.4	7.5	11.1	16	1.8	11	5	6	22	30	KC 7129
73	25	8.2	7.5	11.1	16	1.8	11	5	6	22	30	KC 7034
74	25	8.2	7.5	11.1	12	1.8	11	4	10	25	31	KC 7051
75	25	8.2	7.5	11.1	16	1.8	11	4	10	25	33	KC 7036
76	25	10.2	7.5	11.1	18	1.8	11	5	9	25	34	KC 7131
77	25	10.2	7.5	11.1	16	1.8	11	5	6	22	30	KC 7035
78	25	10.2	7.5	11.1	22	1.8	11	6	14	31	42	KC 7132
79	25	12.7	7.5	11.1	22	1.8	11	6	14	31	42	KC 7037
80	35	6.4	9.0	12.6	16	1.8	12	5	6	23	31	KC 7133
81	35	8.2	9.0	12.6	16	1.8	12	5	6	23	31	KC 7038
82	35	8.2	9.0	12.6	18	1.8	12	5	10	27	36	KC 7134
83	35	10.2	9.0	12.6	18	1.8	12	5	10	27	36	KC 7039
84	35	10.2	9.0	12.6	22	1.8	12	4	15	31	42	KC 7135
85	35	12.7	9.0	12.6	22	1.8	12	4	15	31	42	KC 7040
86	50	8.2	10.5	14.1	18	1.8	16	6	12	34	43	KC 7136
87	50	10.2	10.5	14.1	22	1.8	16	7	9	32	43	KC 7137
88	50	10.2	10.5	14.1	18	1.8	16	6	12	34	43	KC 7041
89	50	10.2	10.5	14.1	24	1.8	16	6	14	36	48	KC 7138
90	50	12.7	10.5	14.1	24	1.8	16	6	14	36	48	KC 7042
91	50	16.2	10.5	14.1	32	1.8	16	7	15	38	54	KC 7139
92	70	10.2	12.0	16.0	22	2.0	18	7	11	36	47	KC 7140
93	70	12.7	12.0	16.0	24	2.0	18	8	10	36	48	KC 7141
94	70	12.7	12.0	16.0	22	2.0	18	7	11	36	47	KC 7043
95	70	16.2	12.0	16.0	28	2.0	18	6	16	40	54	KC 7142
96	95	10.2	13.5	18.1	24	2.3	20	6	12	38	50	KC 7144
97	95	10.2	13.5	18.1	22	2.3	20	5	10	35	46	KC 7143
98	95	12.7	13.5	18.1	24	2.3	20	6	12	38	50	KC 7044
99	95	16.2	13.5	18.1	28	2.3	20	7	17	44	58	KC 7145
100	120	12.7	15.0	20.2	26	2.6	22	10	7	39	52	KC 7146
101	120	16.2	15.0	20.2	32	2.6	22	7	19	48	64	KC 7147
102	120	20.3	15.0	20.2	40	2.6	22	10	20	52	72	KC 7148
103	150	12.7	16.5	23.7	34	3.6	24	9	16	49	66	KC 7149
104	150	16.2	16.5	23.7	34	3.6	24	9	16	49	66	KC 7045
105	150	16.2	16.5	23.7	40	3.6	24	10	20	54	74	KC 7150
106	150	20.3	16.5	23.7	40	3.6	24	10	20	54	74	KC 7046

COPPER TUBULAR END SEALING FERRULES FOR SOLDERLESS CRIMPING TO COPPER OR ALLUMINIUM CONDUCTORS

- Copper BS - 1977
- Electro Tinned finish

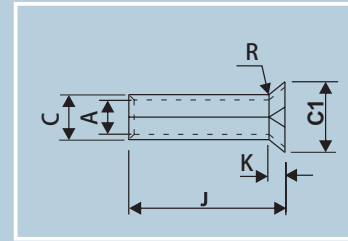

Item No.	AREA mm ²	A	C	C-1 +0 -2	K (Max)	R (Min)	J ±0.4	KAYCEE CAT. No
107	0.5	1.0-1.1	1.4-1.5	2.1	0.7	0.8	6	KCH-508
108	0.75	1.4-1.5	1.8-1.9	2.5	0.7	0.8	6	KCH-509
109	1.0	1.6-1.7	2.0-2.1	2.7	0.7	0.8	6	KCH-510
110	1.0	1.6-1.7	2.0-2.1	2.7	0.7	0.8	10	KCH-511
111	1.5	1.8-1.9	2.2-2.3	2.9	1.0	1.2	7	KCH-512
112	1.5	1.8-1.9	2.2-2.3	2.9	1.0	1.2	10	KCH-513
113	2.5	2.3-2.4	2.7-2.8	3.5	1.0	1.2	7	KCH-514
114	2.5	2.3-2.4	2.7-2.8	3.5	1.0	1.2	12	KCH-515
115	4	2.8-2.9	3.2-3.3	4.0	1.0	1.2	9	KCH-516
116	4	2.8-2.9	3.2-3.3	4.0	1.0	1.2	12	KCH-517
117	6	3.7-3.8	4.1-4.2	4.8	1.0	1.2	10	KCH-518
118	6	3.7-3.8	4.1-4.2	4.8	1.0	1.2	12	KCH-519
119	6	3.7-3.8	4.1-4.2	4.8	1.0	1.2	15	KCH-520
120	10	4.6-4.7	5.0-5.1	5.8	1.2	1.2	12	KCH-521
121	10	4.6-4.7	5.0-5.1	5.8	1.2	1.2	15	KCH-522
122	10	4.6-4.7	5.0-5.1	5.8	1.2	1.2	18	KCH-523
123	16	5.9-6.0	6.3-6.4	7.5	1.5	1.6	12	KCH-524
124	16	5.9-6.0	6.3-6.4	7.5	1.5	1.6	15	KCH-525
125	16	5.9-6.0	6.3-6.4	7.5	1.5	1.6	18	KCH-526

OPEN-CLOSE TYPE SOLDERING CABLE SOCKETS FOR ALUMINIUM CONDUCTORS.

- Copper IS - 1897
- Electro Tinned finish

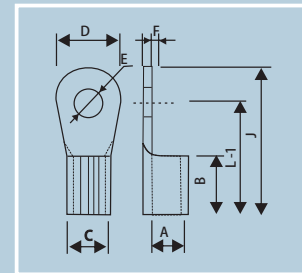

Item No.	AREA mm ²	CABLE SIZE	E	A	C	D	F	B	L-1	J	KAYCEE CAT. No.
126	1.5	1/1.4	4.2	1.6	3.2	7	0.8	5	11.5	15.0	KCOC-371
127	1.5	48/0.2	3.5	2.1	3.7	7	0.8	5	8.0	12.5	KCOC-345
128	2.5	3/1.06	5.2	2.3	3.9	9	0.8	6	13.5	18.0	KCOC-372
129	2.5	80/0.2	5.1	2.6	4.2	9	0.8	5	7.0	16.5	KCOC-344
130	4	7/0.85	5.2	2.8	4.8	9	1.0	6	23.0	20.0	KCOC-373
131	6	7/1.06	6.5	3.6	5.6	12	1.0	7	18.0	24.0	KCOC-374
132	10	7/1.4	6.5	4.4	6.4	12	1.0	9	21.0	27.0	KCOC-375
133	16	7/1.7	8.2	5.4	7.8	15	1.2	11	30.5	32.0	KCOC-376
134	25	7/2.24	8.2	7.0	10.2	15	1.6	14	28.5	36.0	KCOC-377
135	35	7/2.5	8.2	8.0	11.2	18	1.6	15	32.0	41.0	KCOC-378
136	50	19/1.8	10.2	9.5	13.1	24	1.8	18	38.0	50.0	KCOC-379
137	70	19/2.24	10.2	11.8	15.8	28	2.0	23	44.0	58.0	KCOC-380
138	95	19/2.5	12.7	13.5	18.7	32	2.6	25	50.0	66.0	KCOC-381
139	120	37/2.06	12.7	15.5	21.1	34	2.8	29	56.0	73.0	KCOC-382
140	150	37/2.24	12.7	16.5	22.9	38	3.2	30	60.0	79.0	KCOC-383
141	185	37/2.5	16.2	18.5	25.7	42	3.6	35	66.0	87.0	KCOC-384
142	225	37/2.8	16.2	21.1	28.2	44	3.6	40	70.0	92.0	KCOC-385
143	240	61/2.24	16.2	22.5	30.5	48	4.0	42	76.0	100.0	KCOC-386
144	300	61/2.5	20.3	25.0	34.0	54	4.5	45	83.0	110.0	KCOC-387
145	400	61/3.0	20.3	29.5	39.5	62	5.0	54	94.0	125.0	KCOC-388
146	500	91/2.65	20.3	32.0	42.8	62	5.4	58	106.0	137.0	KCOC-389
147	625	91/3.0	20.3	36.0	46.8	70	5.4	65	113.0	148.0	KCOC-390

COPPER TUBULAR TERMINAL ENDS FOR SOLDERLESS CRIMPING TO ALUMINIUM CONDUCTORS

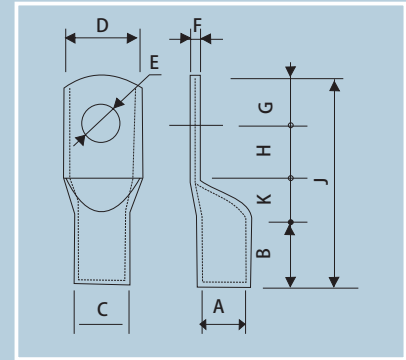

- Copper BS - 1977
- Electro Tinned finish

Item No.	AREA mm ²	CABLE SIZE	E	A	C	D	F	B	K	H	G	J	KAYCEE CAT. No.
148	2.5	1/1.8	5.2	2.0	3.7	9	1.0	7	3	5	5	20	KCUS-05
149	4	1/2.8	6.5	3.1	4.8	11	1.0	7	3	6	6	22	KCUS-06
150	6	1/3.55	6.5	3.8	5.5	11	1.0	9	3	6	6	24	KCUS-07
151	10	7/1.4	6.5	4.4	6.2	11	1.3	9	3	6	6	24	KCUS-08
152	16	7/1.7	6.5	5.3	7.1	11	1.6	12	4	8	6	30	KCUS-09
153	25	7/2.24	6.5	7.0	9.0	13	2.0	12	5	12	8	37	KCUS-10
154	35	7/2.5	6.5	8.0	10.0	15	2.0	12	5	12	8	37	KCUS-11
155	35	7/2.5	8.2	8.0	10.0	15	2.0	12	5	12	8	37	KCUS-12
156	50	19/1.8	6.5	9.2	11.2	16	2.0	16	8	12	9	45	KCUS-13
157	50	19/1.8	8.2	9.2	11.2	16	2.0	16	8	12	9	45	KCUS-14
158	50	19/1.8	10.2	9.2	11.2	16	2.0	16	8	12	9	45	KCUS-15
159	70	19/2.24	8.2	11.5	13.8	20	2.3	18	10	15	13	56	KCUS-16
160	70	19/2.24	10.2	11.5	13.8	20	2.3	18	10	15	13	56	KCUS-17
161	70	19/2.24	12.7	11.5	13.8	20	2.3	18	10	15	13	56	KCUS-18
162	95	19/2.5	10.2	12.8	15.6	23	2.8	20	10	15	13	58	KCUS-19
163	95	19/2.5	12.7	12.8	15.6	23	2.8	20	10	15	13	58	KCUS-20
164	120	37/2.06	10.2	14.8	17.8	26	3.0	22	10	16	14	62	KCUS-21
165	120	37/2.06	12.7	14.8	17.8	26	3.0	22	10	16	14	62	KCUS-22
166	120	37/2.06	16.2	14.8	17.8	26	3.0	22	10	16	14	62	KCUS-23
167	150	37/2.24	10.2	16.0	19.6	28	3.6	26	11	18	15	70	KCUS-24
168	150	37/2.24	12.7	16.0	19.6	28	3.6	26	11	18	15	70	KCUS-25
169	150	37/2.24	16.2	16.0	19.6	28	3.6	26	11	18	15	70	KCUS-26
170	185	37/2.5	12.7	18.0	22.0	32	4.0	28	13	21	21	83	KCUS-27
171	185	37/2.5	16.2	18.0	22.0	32	4.0	28	13	21	21	83	KCUS-28
172	225	37/2.8	16.2	20.0	24.0	35	4.0	32	15	24	24	95	KCUS-231
173	240	61/2.24	16.2	22.0	26.0	38	4.0	34	15	24	24	97	KCUS-29
174	240	61/2.24	20.3	22.0	26.0	38	4.0	34	15	24	24	97	KCUS-30
175	300	61/2.5	16.2	24.0	28.7	42	4.7	36	16	25	25	103	KCUS-31
176	300	61/2.5	20.3	24.0	28.7	42	4.7	36	16	25	25	103	KCUS-32
177	400	61/3.0	20.3	28.0	33.2	49	5.2	44	18	27	27	116	KCUS-33
178	500	91/2.65	20.3	30.0	36.0	53	6.0	48	18	27	27	120	KCUS-34
179	630	91/3.0	20.3	35.0	41.5	61	6.5	53	20	33	31	137	KCUS-35
180	800	91/3.35	-	39.0	46.3	67	7.3	68	25	38	37	165	KCUS-062
181	1000	91/3.75	-	43.0	53.8	76	10.8	90	30	45	45	210	KCUS-076

PRODUCT CATALOGUE

SOLDERING TYPE COPPER TUBULAR SOCKETS SUITABLE FOR ALUMINIUM CONDUCTORS.

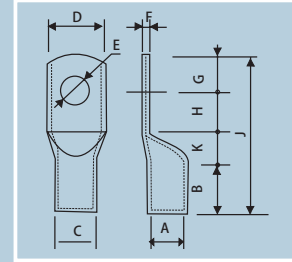

- Copper BS - 1977
- Electro Tinned finish

Item No.	AREA mm ²	CABLE SIZE	E	A	C	D	F	B	K	H	G	J	KAYCEE CAT. No.
182	15	7/1.06	3.2	3.9	4.8	7	0.9	7	2	6	4	19	KCEW-201
183	30	7/1.4	5.1	5.2	6.3	9	1.1	9	3	6	5	23	KCEW-202
184	60	7/2.24	6.4	8.1	9.5	14	1.4	14	4	9	9	36	KCEW-203
185	100	19/1.8	9.5	10.9	12.7	19	1.8	19	8	11	11	49	KCEW-204
186	150	19/2.24	9.5	13.9	15.9	24	2.0	23	8	13	13	57	KCEW-205
187	200	19/2.5	12.7	16.6	19.0	28	2.4	27	11	14	14	66	KCEW-206
188	300	37/2.24	12.7	19.0	22.2	33	3.2	28	13	20	19	80	KCEW-207
189	400	37/2.5	15.9	22.2	25.4	38	3.2	32	15	21	21	89	KCEW-208
190	500	61/2.24	19.0	25.4	28.6	43	3.2	38	17	25	25	105	KCEW-209
191	600	61/2.5	19.0	27.8	31.8	47	4.0	44	17	27	27	115	KCEW-210
192	800	61/3.0	23.8	31.7	38.1	56	6.4	47	18	28	28	121	KCEW-211
193	1000	91/3.0	23.8	38.1	44.5	66	6.4	56	20	42	34	152	KCEW-212
194	1000	91/3.75	----	50.0	57.3	85	7.3	62	20	46	36	164	KCEW-295

COPPER RING TONGUE FORK TERMINAL ENDS ("U" CUT) FOR SOLDERLESS CRIMPING TO COPPER OR ALUMINIUM CONDUCTORS.

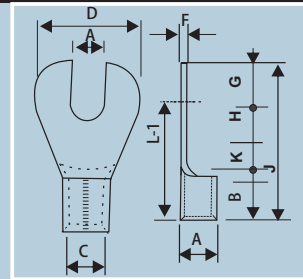

- Copper IS - 1897
- Electro Tinned finish

Item No.	AREA mm ²	E	A	C	D	F	B	K	H	G	L-1	J	KAYCEE CAT. No.
195	1.5	3.1	1.6	3.2	6.0	0.8	5	2	4.0	3.0	11.0	14.0	KC7235
196	1.5	4.1	1.6	3.2	8.0	0.8	5	2	5.0	4.0	12.0	16.0	KC7236
197	1.5	4.1	1.6	3.2	7.0	0.8	5	1	5.0	3.5	11.0	14.0	KC7237
198	1.5	5.1	1.6	3.2	10.0	0.8	5	2	6.0	5.0	13.0	18.0	KC7238
199	1.5	3.6	1.6	3.2	6.0	0.8	5	2	4.0	3.0	11.0	14.0	KC7240
200	1.5	3.1	1.6	3.2	6.8	0.8	5	---	4.6	3.4	9.6	13.0	KC7241
201	1.5	3.6	1.6	3.2	6.8	0.8	5	---	4.6	3.4	9.6	13.0	KC7244
202	1.5	6.1	1.6	3.2	10.0	0.8	5	2	6.0	5.0	13.0	18.0	KC7861
203	2.5	3.1	2.3	3.9	6.5	0.8	5	1	3.5	3.2	9.5	12.7	KC7862
204	2.5	3.6	2.3	3.9	6.5	0.8	5	1	3.5	3.2	9.5	12.7	KC7863
205	2.5	6.1	2.3	3.9	10.0	0.8	5	1	7.0	5.0	13.0	18.0	KC7864
206	2.5	4.1	2.3	3.9	8.0	0.8	5	2	5.0	4.0	12.0	16.0	KC7239
207	2.5	5.1	2.3	3.9	10.0	0.8	5	1	7.0	5.0	13.0	18.0	KC7242
208	4-6	4.1	3.5	5.5	8.0	1.0	6	2	5.0	4.0	13.0	17.0	KC7243
209	4-6	4.1	3.5	5.5	10.0	1.0	6	3	5.0	5.0	14.0	19.0	KC7245
210	4-6	5.1	3.5	5.5	10.0	1.0	6	3	5.0	5.0	14.0	19.0	KC7246
211	4-6	5.1	3.5	5.5	10.0	1.0	6	3	7.0	6.0	16.0	22.0	KC7247
212	4-6	6.1	3.5	5.5	12.0	1.0	6	3	7.0	6.0	16.0	22.0	KC7248
213	10	4.1	4.3	6.3	10.0	1.0	8	2	7.0	5.0	17.0	22.0	KC7865
214	10	5.1	4.3	6.3	10.0	1.0	8	2	7.0	5.0	17.0	22.0	KC7866
215	10	6.1	4.3	6.3	12.0	1.0	8	2	7.0	6.0	17.0	23.0	KC7867
216	10	8.1	4.3	6.3	16.0	1.0	8	4	7.0	8.0	19.0	27.0	KC7868
217	16	5.1	5.6	8.0	10.0	1.2	10	3	6.0	5.0	19.0	24.0	KC7869
218	16	6.1	5.6	8.0	12.0	1.2	10	4	6.0	6.0	20.0	26.0	KC7870
219	16	8.1	5.6	8.0	16.0	1.2	10	4	8.0	8.0	22.0	30.0	KC7871
220	16	8.1	5.6	8.0	18.0	1.2	10	4	10.0	9.0	24.0	33.0	KC7872

COPPER FORK HOOK TERMINAL ENDS

- Copper IS - 1897
- Electro Tinned finish

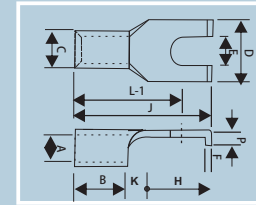

Item No.	AREA mm ²	E	A	C	D	F	B	K	H	L-1	J	P	KAYCEE CAT. No.
221	0.75	2.3	0.9	1.9	4.6	0.5	3	---	5.0	8.0	11	1.2	KC 7279
222	1.5	2.3	1.6	3.2	6.0	0.8	5	---	5.2	3.2	13	1.0	KC 7278
223	1.5	2.3	1.6	3.2	4.6	0.8	5	---	5.2	10.2	13	1.0	KC 7265
224	1.5	4.1	1.7	3.3	7.5	0.8	5	---	6.5	11.5	15	2.4	KC 7266
225	1.5	5.1	1.6	3.2	8.0	0.8	5	2	5.0	12.0	18	1.6	KC 7257
226	1.5	6.3	1.6	3.2	12.0	0.8	5	3	5.0	13.0	19	1.6	KC 7270
227	1.5	8.1	1.6	3.2	12.0	0.8	5	3	5.0	13.0	19	1.6	KC 7271
228	2.5	3.6	2.3	3.9	6.5	0.8	5	2	3	10	15	1.6	KC 7258
229	2.5	4.1	2.3	3.9	7.7	0.8	5	2	3	10	16	1.6	KC 7259
230	2.5	6.3	2.3	3.9	12.0	0.8	5	3	5	13	19	1.6	KC 7272
231	2.5	8.1	2.3	3.9	12.0	0.8	5	3	5	13	19	1.6	KC 7273
232	2.5	5.1	2.3	3.9	10.0	0.8	5	2	5	12	18	1.6	KC 7260
233	4.0	4.1	3.1	5.5	10.0	1.2	6	3	5	14	20	2.0	KC 7274
234	4.0	5.1	3.1	5.5	10.0	1.2	6	3	5	14	20	2.0	KC 7275
235	4.0	6.3	3.1	5.5	12.0	1.2	6	3	5	14	20	2.0	KC 7276
236	4.0	8.1	3.1	5.5	12.0	1.2	6	3	5	14	20	2.0	KC 7277
237	4-6	4.1	3.5	5.5	10.0	1.0	6	3	3	12	18	2.0	KC 7261
238	4-6	5.1	3.5	5.5	10.0	1.0	6	3	5	14	20	2.0	KC 7262
239	4-6	5.1	3.5	5.5	12.0	1.0	6	3	5	14	20	2.0	KC 7263
240	4-6	4.1	3.5	5.5	8.0	1.0	6	2	5	13	17	2.0	KC 7268
241	4-6	5.1	3.5	5.5	8.0	1.0	6	2	5	13	17	2.0	KC 7269
242	6.0	4.1	3.9	5.9	10.0	1.0	6	4	3	13	19	2.0	KC 7264
243	6.0	4.1	3.9	5.9	10.0	1.0	6	---	8.5	14.5	20.5	1.5	KC 7267

COPPER PIN TYPE TERMINAL ENDS FOR SOLDERLESS CRIMPING TO COPPER/ALUMINIUM CONDUCTORS SUITABLE FOR CONTACTORS SWITCHES AND TERMINAL BLOCKS.

- Copper IS - 1897
- Electro Tinned finish

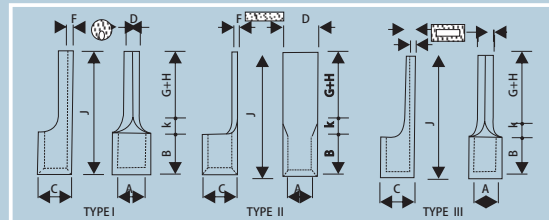

Item No.	AREA mm ²	CZBLE SIZE	A	C	D	F	E	B	K	G+H	J	TYPE	KAYCEE CAT. No.
244	1.5	1/1.40	1.6	3.2	1.9	0.8	---	5	2.0	10	17	I	KCP-9
245	1.5	1/1.40	1.6	3.2	3.1	0.8	---	5	2.0	10	17	II	KCP-35
246	1.5	1/1.50	1.8	3.2	1.9	0.8	---	5	2.0	10	17	I	KCP-38
247	2.5	3/1.06	2.3	3.9	1.9	0.8	---	5	2.0	10	17	I	KCP-1
248	2.5	3/1.06	2.3	3.9	3.1	0.8	---	5	2.0	10	17	II	KCP-2
249	4.0	7/0.85	2.9	4.9	2.7	1.0	---	6	4.0	10	20	I	KCP-3
250	4.0	7/1.06	3.6	5.6	5.1	1.0	---	6	4.0	10	20	II	KCP-4
251	6.0	7/1.06	3.6	5.6	2.7	1.0	---	6	4.0	10	20	I	KCP-5
252	6.0	7/1.2	4.0	6.0	2.7	1.0	---	6	4.0	10	20	I	KCP-6
253	10.0	7/1.4	4.5	6.7	4.3	1.1	2.4	8	2.0	12	22	III	KCP-7
254	16.0	7/1.7	5.8	8.2	5.5	1.2	2.6	10	3.0	13	26	III	KCP-8
255	2.5	---	2.4	4.0	1.7	0.8	1.7	4.2	1.8	8.4	14.4	I	KCP-10
256	2.5	---	2.4	4.0	3.1	0.8	---	4.2	1.8	8.4	14.4	II	KCP-11
257	4.0	1.7	2.8	4.4	1.7	0.8	1.7	4.2	1.8	8.4	14.4	I	KCP-12
258	4.0	---	2.8	4.4	3.1	0.8	---	4.2	1.8	8.4	14.4	II	KCP-13
259	6.0	2.6	3.5	5.5	2.6	1.0	2.6	6.4	1.6	12.4	20.4	I	KCP-14
260	6.0	---	3.5	5.5	5.1	1.0	---	6.4	1.6	12.4	20.4	II	KCP-15
261	10.0	2.6	4.4	6.4	2.6	1.0	2.6	6.4	1.6	12.4	20.4	I	KCP-16
262	25.0	7/2.24	7.5	11.1	7.2	1.8	3.8	11.0	7.0	15	33	III	KCP-125
263	35.0	7/2.5	9.0	12.6	8.2	1.8	3.8	12.0	6.0	15	33	III	KCP-135
264	50.0	19/1.8	10.5	14.1	9.0	1.8	3.8	16.0	8.0	17	41	III	KCP-150
265	70.0	19/2.24	12.0	16.0	10.0	2.0	4.1	16.0	14.0	16	46	III	KCP-170
266	95.0	19/2.5	13.5	18.1	10.0	2.3	4.8	20.0	11.0	20	51	III	KCP-195

COPPER RECTANGULAR TONGUE FORK TERMINAL ENDS FOR SOLDERLESS CRIMPING TO COPPER / ALUMINIUM CONDUCTORS

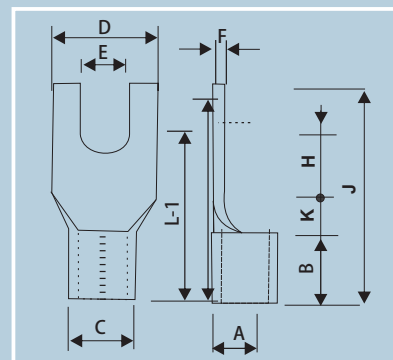

- Copper IS - 1897
- Electro Tinned finish

Item No.	AREA mm ²	E	A	C	D	F	B	K	H	L-1	J-1	KAYCEE CAT. No.
267	1.5	3.0	2.0	2.8	6.2	0.4	5	2.4	3.1	10.5	13	KC8055
268	1.5	3.5	1.6	3.2	6.8	0.8	5	---	4.8	8.8	15	KC7249
269	1.5	3.0	2.0	2.8	6.2	0.4	5	2.4	3.1	10.5	13	KC7250
270	2.5	3.5	2.3	3.9	6.5	0.8	5	2.5	4.3	11.8	15	KC7251
271	2.5	5.0	2.6	4.6	10.6	1.0	6.2	---	6.2	12.4	21	KC7280
272	4-6	3.1	3.5	5.5	6.0	1.0	6	---	5.5	11.5	15	KC7252
273	4-6	3.5	3.5	5.5	6.0	1.0	6	---	5.0	11.0	15	KC7253
274	10	6.5	4.5	6.9	16.0	1.2	8	---	11.0	19.0	27	KC7254
275	10	8.2	4.5	6.9	16.0	1.2	8	---	11.0	19.0	27	KC7255

COPPER PIN TYPE TERMINAL ENDS (INSULATED) FOR SOLDERLESS CRIMPING TO COPPER / ALUMINIUM CONDUCTORS.

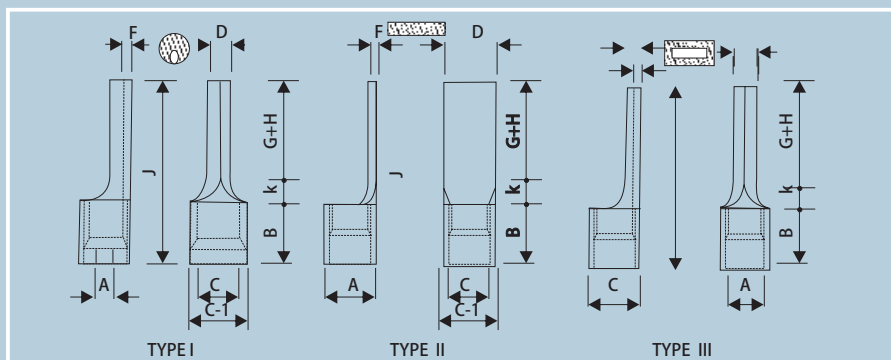

Colour Coding of Insulation Sleeve

Size (mm ²)	Colour
1.5	Red
2.5	Blue
4-6	Yellow

Item No.	AREA mm ²	A	C	D	F	E	B	G+H	J	C-1	J-1	TYPE	KAYCEE CAT. No.
276	1.5	1.6	3.2	1.9	0.8	---	5	10	17	4.8	10	I	KCPI-17
277	1.5	1.6	3.2	3.1	0.8	---	5	10	17	4.8	10	II	KCPI-40
278	1.5	1.8	3.3	1.5	0.75	---	5	15	22	4.8	10	I	KCPI-42
279	1.5	1.5	3.2	1.7	0.8	---	5	10	17	4.8	10	I	KCPI-51
280	2.5	2.3	3.9	1.9	0.8	---	5	10	17	5.5	10	I	KCPI-18
281	2.5	2.3	3.9	3.1	0.8	---	5	10	17	5.5	10	II	KCPI-19
282	4.0	2.9	4.9	2.7	1.0	---	6	10	20	7.1	14	I	KCPI-20
283	4.0	3.6	5.6	5.1	1.0	---	6	10	20	7.1	14	II	KCPI-21
284	6.0	3.6	5.6	2.7	1.0	---	6	10	20	7.1	14	I	KCPI-22
285	6.0	4.0	6.0	2.7	1.0	---	6	10	20	7.1	14	I	KCPI-23
286	10.0	4.5	6.7	4.3	1.1	2.4	8	12	22	7.9	16	III	KCPI-24
287	16.0	5.8	8.2	5.5	1.2	2.6	10	13	26	10.0	20	III	KCPI-25

PRODUCT CATALOGUE

COPPER RING TONGUE TERMINAL FORK ENDS ("U" CUT INSULATED) FOR SOLDERLESS CRIMPING TO COPPER/ALUMINIUM CONDUCTORS.

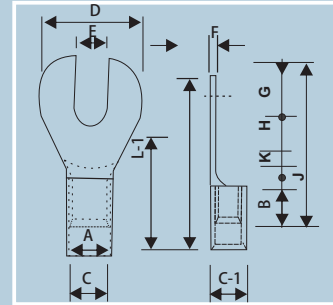

Colour Coding of Insulation Sleeve

Size (mm ²)	Colour
1.5	Red
2.5	Blue
4-6	Yellow

Item No.	AREA mm ²	E	A	C	D	F	B	K	H	G	J	J-1	C-1	L-3	KAYCEE CAT. No.
288	1.5	3.1	1.6	3.2	6.0	0.8	5	2	4.0	3.0	14.0	10	4.8	16	KC7873
289	1.5	3.6	1.6	3.2	6.0	0.8	5	2	4.0	3.0	14.0	10	4.8	16	KC7874
290	1.5	3.1	1.6	3.2	6.8	0.8	5	---	4.6	3.4	13.0	10	4.8	14.6	KC7875
291	1.5	3.6	1.6	3.2	6.8	0.8	5	---	4.6	3.4	13.0	10	4.8	14.6	KC7876
292	1.5	4.1	1.6	3.2	7.0	0.8	5	1	5.0	3.5	14.0	10	4.8	16	KC7877
293	1.5	4.1	1.6	3.2	8.0	0.8	5	2	5.0	4.0	16.0	10	4.8	17	KC7878
294	1.5	5.1	1.6	3.2	10.0	0.8	5	2	6.0	5.0	18.0	10	4.8	18	KC7879
295	1.5	6.1	1.6	3.2	10.0	0.8	5	2	6.0	5.0	18.0	10	4.8	18	KC7880
296	2.5	3.1	2.3	3.9	6.5	0.8	5	1	3.5	3.2	12.7	10	5.5	14.5	KC7881
297	2.5	3.6	2.3	3.9	6.5	0.8	5	1	3.5	3.2	12.7	10	5.5	14.5	KC7882
298	2.5	4.1	2.3	3.9	8.0	0.8	5	2	5.0	4.0	16.0	10	5.5	17	KC7883
299	2.5	5.1	2.3	3.9	10.0	0.8	5	1	7.0	5.0	18.0	10	5.5	18	KC7884
300	2.5	6.1	2.3	3.9	10.0	0.8	5	1	7.0	5.0	18.0	10	5.5	18	KC7885
301	4-6	4.1	3.5	5.5	8.0	1.0	6	2	5.0	4.0	17.0	14	7.1	21	KC7886
302	4-6	4.1	3.5	5.5	10.0	1.0	6	3	5.0	5.0	19.0	14	7.1	22	KC7887
303	4-6	5.1	3.5	5.5	10.0	1.0	6	3	5.0	5.0	19.0	14	7.1	22	KC7888
304	4-6	5.1	3.5	5.5	12.0	1.0	6	3	7.0	6.0	22.0	14	7.1	24	KC7889
305	4-6	6.1	3.5	5.5	12.0	1.0	6	3	7.0	6.0	22.0	14	7.1	24	KC7890
306	10	4.1	4.3	6.3	10.0	1.0	8	2	7.0	5.0	22.0	16	7.9	25	KC7891
307	10	5.1	4.3	6.3	10.0	1.0	8	2	7.0	5.0	22.0	16	7.9	25	KC7892
308	10	6.1	4.3	6.3	12.0	1.0	8	2	7.0	6.0	23.0	16	7.9	25	KC7893
309	10	8.1	4.3	6.3	16.0	1.0	8	4	7.0	8.0	27.0	16	7.9	27	KC7894
310	16	5.1	5.6	8.0	10.0	1.2	10	3	6.0	5.0	24.0	20	10.0	29	KC7895
311	16	6.1	5.6	8.0	12.0	1.2	10	4	6.0	6.0	26.0	20	10.0	30	KC7896
312	16	8.1	5.6	8.0	16.0	1.2	10	4	8.0	8.0	30.0	20	10.0	32	KC7897
313	16	8.1	5.6	8.0	18.0	1.2	10	4	10.0	9.0	33.0	20	10.0	34	KC7898

COPPER RECTANGULAR TONGUE FORK TERMINAL ENDS (INSULATED) FOR SOLDERLESS CRIMPING TO COPPER OR ALUMINIUM CONDUCTORS.

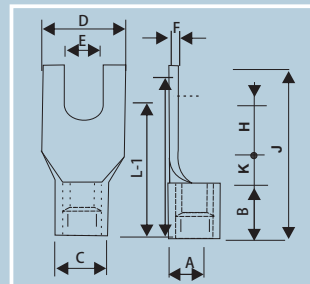

Colour Coding of Insulation Sleeve

Size (mm ²)	Colour
1.5	Red
2.5	Blue
4-6	Yellow

Item No.	AREA mm ²	E	A	C	D	F	B	K	H	J	C-1	J-1	L-3	KAYCEE CAT. No.
314	1.5	5.1	1.6	3.2	8.0	0.8	5	2.0	10.0	21	4.8	10	27.0	KC7925
315	1.5	3.5	1.6	3.2	6.8	0.8	5	-	4.8	15	4.8	10	20.8	KC7926
316	1.5	3.0	2.0	2.8	6.2	0.4	5	2.4	3.1	13	4.8	10	20.5	KC7927
317	2.5	3.5	2.3	3.9	6.5	0.8	5	2.5	4.3	15	5.5	10	21.8	KC7928
318	2.5	5.0	2.6	4.6	10.6	1.6	6.2	-	6.2	21	5.5	10	20.0	KC7929
319	4-6	3.1	3.5	5.5	6.0	1.0	6	---	5.5	15	7.1	14	27.5	KC7930
320	4-6	3.5	3.5	5.5	6.0	1.0	6	---	5.0	15	7.1	14	27.0	KC7931
321	10	6.5	4.5	6.9	16.0	1.2	8	---	11.0	27	7.9	16	35.0	KC7932
322	10	8.2	4.5	6.9	16.0	1.2	8	---	11.0	27	7.9	16	35.0	KC7933

PRODUCT CATALOGUE

COPPER RING TONGUE TERMINAL ENDS (INSULATED) FOR SOLDERLESS CRIMPING TO COPPER / ALUMINIUM CONDUCTORS.

Colour Coding of Insulation Sleeve

Size (mm ²)	Colour
1.5	Red
2.5	Blue
4-6	Yellow

- Copper IS - 1897
- Electro Tinned finish

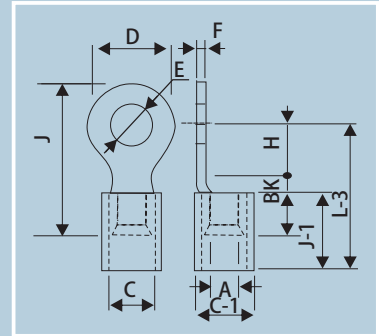

Item No.	AREA mm ²	E	A	C	D	F	B	K	H	J	J-1	L-3	C-1	KAYCEE CAT. No.
323	1.5	2.2	1.6	3.2	6	0.8	5	2	4	14	10	16	4.8	KC 7052
324	1.5	2.6	1.6	3.2	6	0.8	5	2	4	14	10	16	4.8	KC 7053
325	1.5	3.2	1.6	3.2	6	0.8	5	2	4	14	10	16	4.8	KC 7054
326	1.5	3.2	1.6	3.2	6.8	0.8	5	1	3.6	13	10	14.6	4.8	KC 7057
327	1.5	3.2	1.6	3.2	8	0.8	5	2	5	16	10	17	4.8	KC 7060
328	1.5	3.7	1.6	3.2	6	0.8	5	2	4	14	10	16	4.8	KC 7055
329	1.5	3.7	1.6	3.2	6.8	0.8	5	1	3.6	13	10	14.6	4.8	KC 7058
330	1.5	4.2	1.6	3.2	6	0.8	5	2	4	14	10	16	4.8	KC 7056
331	1.5	4.2	1.6	3.2	6.8	0.8	5	1	3.6	13	10	14.6	4.8	KC 7059
332	1.5	4.2	1.6	3.2	8	0.8	5	2	5	16	10	17	4.8	KC 7061
333	1.5	4.2	1.6	3.2	10	0.8	5	2	6	18	10	18	4.8	KC 7064
334	1.5	4.2	1.6	3.2	7	0.8	5	1	5	14.5	10	16	4.8	KC 7063
335	1.5	5.2	1.6	3.2	8	0.8	5	2	5	16	10	17	4.8	KC 7062
336	1.5	5.2	1.6	3.2	10	0.8	5	2	6	18	10	18	4.8	KC 7065
337	1.5	6.4	1.6	3.2	10	0.8	5	2	6	18	10	18	4.8	KC 7066
338	1.5	6.4	1.6	3.2	12	0.8	5	1	6	18	10	17	4.8	KC 7067
339	2.5	3.2	2.3	3.9	6.5	0.8	5	1	3.5	12.7	10	14.5	5.5	KC 7068
340	2.5	3.7	2.3	3.9	6.5	0.8	5	1	3.5	12.7	10	14.5	5.5	KC 7069
341	2.5	3.7	2.3	3.9	8	0.8	5	2	5	16	10	17	5.5	KC 7070
342	2.5	4.2	2.3	3.9	8	0.8	5	2	5	16	10	17	5.5	KC 7071
343	2.5	5.2	2.3	3.9	8	0.8	5	2	5	16	10	17	5.5	KC 7072
344	2.5	5.2	2.3	3.9	10	0.8	5	1	7	18	10	18	5.5	KC 7073
345	2.5	5.2	2.3	3.9	12	0.8	5	2	9	22	10	21	5.5	KC 7075
346	2.5	8.2	2.3	3.9	12	0.8	5	2	9	22	10	21	5.5	KC 7077
347	2.5	6.4	2.3	3.9	10	0.8	5	1	7	18	10	18	5.5	KC 7074
348	2.5	6.4	2.3	3.9	12	0.8	5	2	9	22	10	21	5.5	KC 7076
349	2.5	8.2	2.3	3.9	16	0.8	5	2	10	25	10	22	5.5	KC 7079
350	2.5	6.4	2.3	3.9	16	0.8	5	2	10	25	10	22	5.5	KC 7078
351	2.5	10.2	2.3	3.9	16	0.8	5	2	10	25	10	22	5.5	KC 7080
352	2.5	10.2	2.3	3.9	18	0.8	5	1	14	29	10	25	5.5	KC 7081
353	2.5	12.7	2.3	3.9	18	0.8	5	1	14	29	10	25	5.5	KC 7082
354	4-6	4.2	3.5	5.5	8	1.0	6	2	5	17	14	21	7.1	KC 7083
355	4-6	4.2	3.5	5.5	10	1.0	6	3	5	19	14	22	7.1	KC 7085
356	4-6	5.2	3.5	5.5	8	1.0	6	2	5	17	14	21	7.1	KC 7084
357	4-6	5.2	3.5	5.5	10	1.0	6	3	5.0	19.0	14	22.0	7.1	KC 7086
358	4-6	5.2	3.5	5.5	8	1.0	6	3	9.0	22.0	14	26.0	7.1	KC 7087
359	4-6	5.2	3.5	5.5	12	1.0	6	2	6	20	14	22	7.1	KC 7088
360	4-6	5.2	3.5	5.5	12	1.0	6	3	7	22	14	24	7.1	KC 7091
361	4-6	6.4	3.5	5.5	12	1.0	6	2	6.0	20.0	14	22.0	7.1	KC 7089
362	4-6	6.4	3.5	5.5	12	1.0	6	3	7.0	22.0	14	24.0	7.1	KC 7092
363	4-6	6.4	3.5	5.5	14	1.0	6	2	10.5	25.5	14	26.5	7.1	KC 7093
364	4-6	6.4	3.5	5.5	16	1.0	6	3	13.0	30.0	14	30.0	7.1	KC 7096
365	4-6	6.4	3.5	5.5	18	1.0	6	3	12.0	30.0	14	29.0	7.1	KC 7099
366	4-6	8.2	3.5	5.5	14	1.0	6	2	10.5	25.5	14	26.5	7.1	KC 7094
367	4-6	8.2	3.5	5.5	12	1.0	6	2	6.0	20.0	14	22.0	7.1	KC 7090.
368	4-6	8.2	3.5	5.5	18	1.0	6	3	12.0	30.0	14	29.0	7.1	KC 7100
369	4-6	8.2	3.5	5.5	18	1.0	6	3	12	30	14	30	7.1	KC 7098
370	4-6	9.7	3.5	5.5	14	1.0	6	2	10.5	25.5	14	26.5	7.1	KC 7095
371	4-6	10.2	3.5	5.5	16	1.0	6	3	13	30	14	30	7.1	KC 7097

PRODUCT CATALOGUE

COPPER FORK HOOK TERMINAL ENDS (INSULATED)

Colour Coding of Insulation Sleeve

Size (mm ²)	Colour
0.75	Yellow
1.5	Red
2.5	Blue
4-6	Yellow

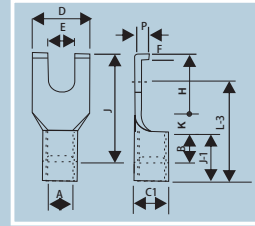

Item No.	AREA mm ²	E	A	C	D	F	B	K	H	J	J-1	A-1	C-1	L-3	KAYCEE CAT. No.
372	0.75	2.3	0.9	1.9	4.6	0.5	3	---	5	11	1.2	3.2	8	13.0	KC 7943
373	1.5	2.3	1.6	3.2	6.0	0.8	5	---	5.2	13	1.0	4.8	10	20.2	KC 7944
374	1.5	2.3	1.6	3.2	4.6	0.8	5	---	5.2	13	1.0	4.8	10	20.0	KC 7945
375	1.5	4.1	1.7	3.3	7.5	0.8	5	---	6.5	15	2.4	4.8	10	21.5	KC 7946
376	1.5	3.5	1.6	3.2	6.8	0.8	5	2	3	15	1.6	4.8	10	20.0	KC 7947
377	1.5	5.1	1.6	3.2	8.0	0.8	5	2	5	18	1.6	4.8	10	22.0	KC 7948
378	1.5	6.3	1.6	3.2	12.0	0.8	5	3	5	19	1.6	4.8	10	23.0	KC 7949
379	1.5	8.1	1.6	3.2	12.0	0.8	5	3	5	19	1.6	4.8	10	23.0	KC 7950
380	2.5	3.6	2.3	3.9	6.5	0.8	5	2	3	15	1.6	5.5	10	20.0	KC 7951
381	2.5	4.1	2.3	3.9	7.7	0.8	5	2	3	16	1.6	5.5	10	20.0	KC 7952
382	2.5	5.1	2.3	3.9	10.0	0.8	5	2	5	18	1.6	5.5	10	22.0	KC 7953
383	2.5	6.3	2.3	3.9	12.0	0.8	5	3	5	19	1.6	5.5	10	23.0	KC 7954
384	2.5	8.1	2.3	3.9	12.0	0.8	5	3	5	19	1.6	5.5	10	23.0	KC 7955
385	4-6	4.1	3.1	5.5	10.0	1.2	6	3	5	20	2.0	7.1	14	30.0	KC 7956
386	4-6	4.1	3.5	5.5	10.0	1.0	6	3	3	18	2.0	7.1	14	28.0	KC 7960
387	4-6	4.1	3.5	5.5	8.0	1.0	6	2	5	17	2.0	7.1	14	29.0	KC 7963
388	4-6	5.1	3.5	5.5	8.0	1.0	6	2	5	17	2.0	7.1	14	29.0	KC 7964

COPPER RING TONGUE FORK TERMINAL ENDS ("U" CUT INSULATED WITH METAL RENFORCEMENT) FOR SOLDERLESS CRIMPING TO COPPER/ALUMINIUM CONDUCTORS

Colour Coding of Insulation Sleeve

Size (mm ²)	Colour
1.5	Red
2.5	Blue
4-6	Yellow

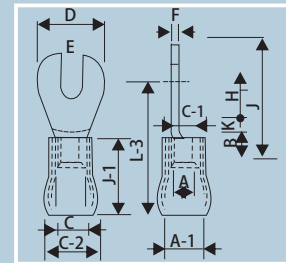

Item No.	AREA mm ²	E	A	C	D	F	B	K	H	J	J-1	A-1	C-1	C-2	L-3	KAYCEE CAT. No.
389	1.5	3.1	1.6	3.2	6	0.8	5	2	4	14	10	3.6	4.8	5.4	16	KC7899
390	1.5	3.1	1.6	3.2	6.8	0.8	5	-	4.6	13	10	3.6	4.8	5.4	14.6	KC7901
391	1.5	3.6	1.6	3.2	6	0.8	5	2	4	14	10	3.6	4.8	5.4	16	KC7900
392	1.5	3.6	1.6	3.2	6.8	0.8	5	-	4.6	13	10	3.6	4.8	5.4	14.6	KC7902
393	1.5	4.1	1.6	3.2	7	0.8	5	1	5	14	10	3.6	4.8	5.4	16	KC7903
394	1.5	4.1	1.6	3.2	8	0.8	5	2	5	16	10	3.6	4.8	5.4	17	KC7904
395	1.5	5.1	1.6	3.2	10	0.8	5	2	6	18	10	3.6	4.8	5.4	18	KC7905
396	1.5	6.1	1.6	3.2	10	0.8	5	2	6	18	10	3.6	4.8	5.4	18	KC7906
397	2.5	3.1	2.3	3.9	6.5	0.8	5	1	3.5	12.7	10	4.4	5.4	6.0	14.5	KC7907
398	2.5	3.6	2.3	3.9	6.5	0.8	5	1	3.5	12.7	10	4.4	5.4	6.0	14.5	KC7908
399	2.5	4.1	2.3	3.9	8	0.8	5	2	5	16	10	4.4	5.4	6.0	17	KC7909
400	2.5	5.1	2.3	3.9	10	0.8	5	1	7	18	10	4.4	5.4	6.0	18	KC7910
401	2.5	6.1	2.3	3.9	10	0.8	5	1	7	18	10	4.4	5.4	6.0	18	KC7911
402	4-6	4.1	3.5	5.5	8	1.0	6	2	5	17	15	6.4	7.1	8.6	22	KC7912
403	4-6	4.1	3.5	5.5	10	1.0	6	3	5	19	15	6.4	7.1	8.6	23	KC7913
404	4-6	5.1	3.5	5.5	10	1.0	6	3	5	19	15	6.4	7.1	8.6	23	KC7914
405	4-6	5.1	3.5	5.5	12	1.0	6	3	7	22	15	6.4	7.1	8.6	25	KC7915
406	4-6	6.1	3.5	5.5	12	1.0	6	3	7	22	15	6.4	7.1	8.6	25	KC7916
407	10	4.1	4.3	6.3	10	1.0	8	2	7	22	17	6.8	8.3	9.5	26	KC7917
408	10	5.1	4.3	6.3	10	1.0	8	2	7	22	17	6.8	8.3	9.5	26	KC7918
409	10	6.1	4.3	6.3	12	1.0	8	2	7	23	17	6.8	8.3	9.5	26	KC7919
410	10	8.1	4.3	6.3	16	1.0	8	4	7	27	17	6.8	8.3	9.5	28	KC7920
411	16	5.1	5.6	8.0	10	1.2	10	3	6	24	23	10.9	9.9	12.9	32	KC7921
412	16	6.1	5.6	8.0	12	1.2	10	4	6	26	23	10.9	9.9	12.9	33	KC7922
413	16	8.1	5.6	8.0	16	1.2	10	4	8	30	23	10.9	9.9	12.9	35	KC7923
414	16	8.1	5.6	8.0	18	1.2	10	4	10	33	23	10.9	9.9	12.9	37	KC7924

PRODUCT CATALOGUE



KAYCEE
Brand that set the standards

COPPER RING TONGUE TERMINAL ENDS (INSULATED WITH METAL REINFORCEMENT) FOR SOLDERLESS CRIMPING TO COPPER OR ALUMINIUM CONDUCTORS.

Colour Coding of Insulation Sleeve

Size (mm ²)	Colour
1.5	Red
2.5	Blue
4-6	Yellow

- Copper IS - 1897
- Electro Tinned finish

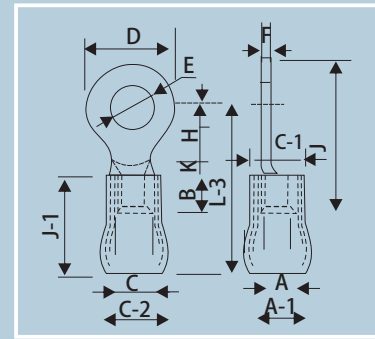

Item No.	AREA mm ²	E	A	C	D	F	B	K	H	J	J-1	A-1	C-1	C-2	L-3	KAYCEE CAT. No.
415	1.5	2.2	1.6	3.2	6.0	0.8	5	2	4.0	14.0	10	3.6	4.8	5.4	16.0	KC 7435
416	1.5	2.6	1.6	3.2	6.0	0.8	5	2	4.0	14.0	10	3.6	4.8	5.4	16.0	KC 7436
117	1.5	3.2	1.6	3.2	6.0	0.8	5	2	4.0	14.0	10	3.6	4.8	5.4	16.0	KC 7437
418	1.5	3.2	1.6	3.2	6.8	0.8	4	1	3.0	11.4	10	3.6	4.8	5.4	14.6	KC 7440
419	1.5	3.2	1.6	3.2	8.0	0.8	5	2	5.0	16.0	10	3.6	4.8	5.4	17.0	KC 7443
420	1.5	3.7	1.6	3.2	6.0	0.8	5	2	4.0	14.0	10	3.6	4.8	5.4	16.0	KC 7438
421	1.5	3.7	1.6	3.2	6.8	0.8	4	1	3.0	11.4	10	3.6	4.8	5.4	14.6	KC 7441
422	1.5	4.2	1.6	3.2	6.0	0.8	5	2	4.0	14.0	10	3.6	4.8	5.4	16.0	KC 7439
423	1.5	4.2	1.6	3.2	6.8	0.8	4	1	3.0	11.4	10	3.6	4.8	5.4	14.6	KC 7442
424	1.5	4.2	1.6	3.2	8.0	0.8	5	2	5.0	16.0	10	3.6	4.8	5.4	17.0	KC 7444
425	1.5	4.2	1.6	3.2	10.0	0.8	5	2	6.0	18.0	10	3.6	4.8	5.4	18.0	KC 7447
426	1.5	4.2	1.6	3.2	7.0	0.8	5	1	5.0	14.5	10	3.6	4.8	5.4	16.0	KC 7446
427	1.5	5.2	1.6	3.2	8.0	0.8	5	2	5.0	16.0	10	3.6	4.8	5.4	17.0	KC 7445
428	1.5	5.2	1.6	3.2	10.0	0.8	5	2	6.0	18.0	10	3.6	4.8	5.4	18.0	KC 7448
429	1.5	6.4	1.6	3.2	10.0	0.8	5	2	6.0	18.0	10	3.6	4.8	5.4	18.0	KC 7449
430	1.5	6.4	1.6	3.2	12.0	0.8	5	1	6.0	18.0	10	3.6	4.8	5.4	17.0	KC 7450
431	2.5	3.2	2.3	3.9	6.5	0.8	5	1	3.5	12.7	10	4.4	5.4	6.0	17.7	KC 7451
432	2.5	3.7	2.3	3.9	6.5	0.8	5	1	3.5	12.7	10	4.4	5.4	6.0	17.7	KC 7452
433	2.5	3.7	2.3	3.9	8.0	0.8	5	2	5.0	16.0	10	4.4	5.4	6.0	17.0	KC 7453
434	2.5	4.2	2.3	3.9	8.0	0.8	5	2	5.0	16.0	10	4.4	5.4	6.0	17.0	KC 7454
435	2.5	5.2	2.3	3.9	8.0	0.8	5	2	5.0	16.0	10	4.4	5.4	6.0	17.0	KC 7455
436	2.5	5.2	2.3	3.9	10.0	0.8	5	1	7.0	18.0	10	4.4	5.4	6.0	18.0	KC 7456
437	2.5	6.4	2.3	3.9	10.0	0.8	5	1	7.0	18.0	10	4.4	5.4	6.0	18.0	KC 7457
438	2.5	6.4	2.3	3.9	12.0	0.8	5	2	9.0	22.0	10	4.4	5.4	6.0	21.0	KC 7459
439	2.5	5.2	2.3	3.9	12.0	0.8	5	2	9.0	22.0	10	4.4	5.4	6.0	21.0	KC 7458
440	2.5	6.4	2.3	3.9	16.0	0.8	5	2	10.0	25.0	10	4.4	5.4	6.0	22.0	KC 7461
441	2.5	8.2	2.3	3.9	12.0	0.8	5	2	9.0	22.0	10	4.4	5.4	6.0	21.0	KC 7460
442	2.5	8.2	2.3	3.9	16.0	0.8	5	2	10.0	25.0	10	4.4	5.4	6.0	22.0	KC 7462
443	2.5	10.2	2.3	3.9	16.0	0.8	5	2	10.0	25.0	10	4.4	5.4	6.0	22.0	KC 7463
444	2.5	10.2	2.3	3.9	18.0	0.8	5	1	14.0	29.0	10	4.4	5.4	6.0	25.0	KC 7464
445	2.5	10.2	2.3	3.9	16	0.8	5	2	10.0	17.0	10	4.4	5.4	6.0	25.0	KC 7015
446	2.5	12.7	2.3	3.9	18.0	0.8	5	1	14.0	29.0	10	4.4	5.4	6.0	25.0	KC 7465
447	4-6	4.2	3.5	5.5	8.0	1.0	6	2	5.0	17.0	15	6.4	7.1	8.6	22.0	KC 7466
448	4-6	4.2	3.5	5.5	10.0	1.0	6	3	5.0	19.0	15	6.4	7.1	8.6	23.0	KC 7468
449	4-6	5.2	3.5	5.5	8.0	1.0	6	2	5.0	17.0	15	6.4	7.1	8.6	22.0	KC 7467
450	4-6	5.2	3.5	5.5	10.0	1.0	6	3	5.0	19.0	15	6.4	7.1	8.6	23.0	KC 7469
451	4-6	5.2	3.5	5.5	8.0	1.0	6	3	9.8	22.8	15	6.4	7.1	8.6	31.8	KC 7470
452	4-6	5.2	3.5	5.5	12.0	1.0	6	2	6.0	22.0	15	6.4	7.1	8.6	23.0	KC 7471
453	4-6	5.2	3.5	5.5	12.0	1.0	6	3	7.0	22.0	15	6.4	7.1	8.6	25.0	KC 7474
454	4-6	6.4	3.5	5.5	12.0	1.0	6	2	6.0	20.0	15	6.4	7.1	8.6	23.0	KC 7472
455	4-6	6.4	3.5	5.5	12.0	1.0	6	3	7.0	22.0	15	6.4	7.1	8.6	25.0	KC 7475
456	4-6	6.4	3.5	5.5	14.0	1.0	6	2	10.5	25.5	15	6.4	7.1	8.6	27.5	KC 7476
457	4-6	12.7	3.5	5.5	18	1.0	6	3	12.0	30.0	15	6.4	7.1	8.6	30.0	KC 7483
458	4-6	8.2	3.5	5.5	12.0	1.0	6	2	6.0	20.0	15	6.4	7.1	8.6	23.0	KC 7473
459	4-6	8.2	3.5	5.5	14.0	1.0	6	2	10.5	25.5	15	6.4	7.1	8.6	27.5	KC 7477
460	4-6	8.2	3.5	5.5	16	1.0	6	3	13.0	30.0	15	6.4	7.1	8.6	31.0	KC 7479
461	4-6	8.2	3.5	5.5	18	1.0	6	3	12.0	30.0	15	6.4	7.1	8.6	30.0	KC 7481
462	4-6	9.7	3.5	5.5	14	1.0	6	2	10.5	25.5	15	6.4	7.1	8.6	27.5	KC 7478
463	4-6	10.2	3.5	5.5	16	1.0	6	3	13.0	30.0	15	6.4	7.1	8.6	31.0	KC 7480
464	4-6	10.2	3.5	5.5	18	1.0	6	3	12.0	30.0	15	6.4	7.1	8.6	30.0	KC 7482

PRODUCT CATALOGUE

**COPPER RING TONGUE TERMINAL ENDS
 (INSULATED WITH METAL REINFORCEMENT)
 FOR SOLDERLESS CRIMPING
 TO COPPER /ALUMINIUM CONDUCTORS.**

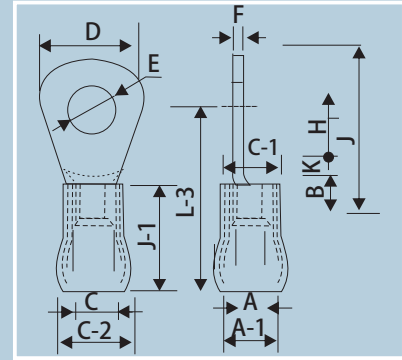

Colour Coding of Insulation Sleeve-Black

- Copper IS - 1897
- Electro Tinned finish

Item No.	AREA mm ²	E	A	C	D	F	B	K	H	J	J-1	A-1	C-1	C-2	L-3	KAYCEE CAT. No.
465	10	4.2	4.3	6.3	10	1.0	8	2	7	22	17	6.8	8.3	9.5	26	KC7484
466	10	5.2	4.3	6.3	10	1.0	8	2	7	22	17	6.8	8.3	9.5	26	KC7486
467	10	4.2	4.3	6.3	10	1.0	8	3	4	20	17	6.8	8.3	9.5	24	KC7485
468	10	5.2	4.3	6.3	10	1.0	8	3	4	20	17	6.8	8.3	9.5	24	KC7487
469	10	6.4	4.3	6.3	12	1.0	8	2	7	23	17	6.8	8.3	9.5	26	KC7488
470	10	8.2	4.3	6.3	16	1.0	8	4	7	27	17	6.8	8.3	9.5	28	KC7489
471	10	8.2	4.3	6.3	18	1.0	8	4	9	30	17	6.8	8.3	9.5	30	KC7490
472	10	10.2	4.3	6.3	18	1.0	8	4	9	30	17	6.8	8.3	9.5	30	KC7491
473	10	10.2	4.3	6.3	22	1.0	8	5	10	34	17	6.8	8.3	9.5	32	KC7492
474	10	12.7	4.3	6.3	22	1.0	8	5	10	34	17	6.8	8.3	9.5	32	KC7493
475	16	5.2	5.6	8.0	10	1.2	10	3	6	24	23	10.9	9.9	12.9	32	KC7494
476	16	5.2	5.6	8.0	12	1.2	10	4	6	26	23	10.9	9.9	12.9	33	KC7495
477	16	6.4	5.6	8.0	12	1.2	10	4	6	26	23	10.9	9.9	12.9	33	KC7496
478	16	6.4	5.6	8.0	16	1.2	10	4	8	30	23	10.9	9.9	12.9	35	KC7497
479	16	8.2	5.6	8.0	16	1.2	10	4	8	30	23	10.9	9.9	12.9	35	KC7498
480	16	9.7	5.6	8.0	16	1.2	10	4	8	30	23	10.9	9.9	12.9	35	KC7499
481	16	8.2	5.6	8.0	18	1.2	10	4	10	33	23	10.9	9.9	12.9	37	KC7500
482	16	10.2	5.6	8.0	18	1.2	10	4	10	33	23	10.9	9.9	12.9	37	KC7501
483	16	10.2	5.6	8.0	22	1.2	10	6	8	35	23	10.9	9.9	12.9	37	KC7502
484	16	12.7	5.6	8.0	22	1.2	10	6	8	35	23	10.9	9.9	12.9	37	KC7503

**COPPER RECTAGULAR FORK TONGUE TERMINAL ENDS
 (INSULATED WITH METAL REINFORCEMENT)
 FOR SOLDERLESS CRIMPING TO COPPER OR ALUMINIUM CONDUCTORS.**

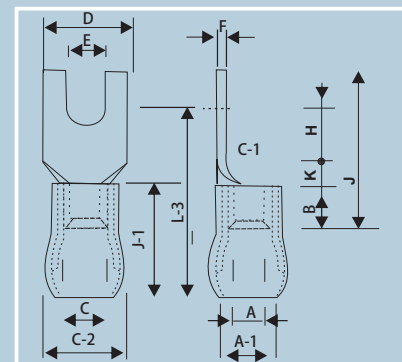

Colour Coding of Insulation Sleeve
 Size (mm²) Colour
 1.5 Red
 2.5 Blue
 4-6 Yellow

Item No.	AREA mm ²	E	A	C	D	F	B	K	H	J	J-1	A-1	C-1	L-3	C-2	KAYCEE CAT. No.
485	1.5	5.1	1.6	3.2	8.0	0.8	5	2.0	10.0	21	10	3.6	4.8	22.0	5.4	KC7934
486	1.5	3.5	1.6	3.2	6.8	0.8	5	---	4.8	15	10	3.6	4.8	14.8	5.4	KC7935
487	1.5	3.0	2.0	2.8	6.2	0.4	5	2.4	3.1	13	10	3.6	4.8	15.5	5.4	KC7936
488	2.5	3.5	2.3	3.9	6.5	0.8	5	2.5	4.3	15	10	4.4	5.4	16.8	6.0	KC7937
489	2.5	5.0	2.6	4.6	10.6	1.0	6.2	---	6.2	21	10	4.4	5.4	16.2	6.0	KC7938
490	4-6	3.1	3.5	5.5	6.0	1.0	6	---	5.5	15	15	6.4	7.1	20.5	8.6	KC7939
491	4-6	3.5	3.5	5.5	6.0	1.0	6	---	5.0	15	15	6.4	7.1	20.0	8.6	KC7940
492	10.0	6.5	4.5	6.9	16.0	1.2	8	---	11.0	27	17	6.8	8.3	28.0	9.5	KC7941
493	10.0	8.2	4.5	6.9	16.0	1.2	8	---	11.0	27	17	6.8	8.3	28.0	9.5	KC7942

**COPPER PIN TYPE TERMINAL ENDS
(INSULATED WITH METAL
REINFORCEMENT)
FOR SOLDERLESS CRIMPING
TO COPPER / ALUMINIUM
CONDUCTORS.**

Colour Coding of Insulation Sleeve

Size (mm ²)	Colour
1.5	Red
2.5	Blue
4-6	Yellow

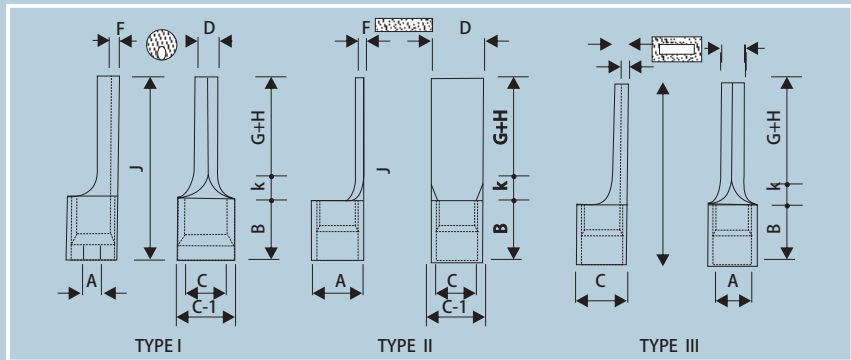

Item No.	AREA mm ²	A	C	D	F	B	G+H	J	J-1	A-1	C-1	C-2	TYPE	KAYCEE CAT. No.
494	1.5	1.6	3.2	1.9	0.8	5	10	17	10	3.6	4.8	5.4	I	KCPD-26
495	2.5	2.3	3.9	1.9	0.8	5	10	17	10	4.4	5.4	6.0	I	KCPD-27
496	2.5	2.3	3.9	3.1	0.8	5	10	17	10	4.4	5.4	6.0	II	KCPD-28
497	4.0	2.9	4.9	2.7	1.0	6	10	20	15	6.4	7.2	8.6	I	KCPD-29
498	4.0	3.6	5.6	5.1	1.0	6	10	20	15	6.4	7.2	8.6	II	KCPD-30
499	6.0	3.6	5.6	2.7	1.0	6	10	20	15	6.4	7.2	8.6	I	KCPD-31
500	6.0	4.0	6.0	2.7	1.0	6	10	20	15	6.4	7.2	8.6	I	KCPD-32
501	2.5	2.3	3.9	1.7	0.8	5	15	22	10	4.4	5.4	6.0	I	KCPD-52
502	10.0	4.5	6.7	4.3	1.1	8	12	22	17	6.8	8.3	9.5	I	KCPD-33
503	16.0	5.8	8.2	5.5	1.2	10	13	26	23	10.9	9.9	12.9	I	KCPD-34

COPPER FORK HOOK TERMINAL ENDS (INSULATED WITH METAL REINFORCEMENT)

Colour Coding of Insulation Sleeve

Size (mm ²)	Colour
0.75	Yellow
1.5	Red
2.5	Blue
4-6	Yellow

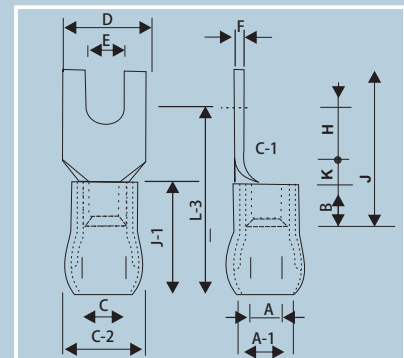

Item No.	AREA mm ²	E	A	C	D	F	B	K	H	J	P	J-1	A-1	C-1	C-2	L-3	KAYCEE CAT. No.
504	0.75	2.3	0.9	1.9	4.6	0.5	3	---	5.0	11	1.2	8	2.2	3.1	3.4	13.0	KC 7967
505	1.5	2.3	1.6	3.2	6.0	0.8	5	---	5.2	13	1.0	10	3.6	4.8	5.4	20.2	KC 7968
506	1.5	2.3	1.6	3.2	4.6	0.8	5	---	5.2	13	1.0	10	3.6	4.8	5.4	20.2	KC 7969
507	1.5	4.1	1.7	3.3	7.5	0.8	5	---	6.5	15	2.4	10	3.6	4.8	5.4	21.5	KC 7970
508	1.5	3.6	1.6	3.2	6.8	0.8	5	2	3	15	1.6	10	3.6	4.8	5.4	20.0	KC 7971
509	1.5	5.1	1.6	3.2	8.0	0.8	5	2	5	18	1.6	10	3.6	4.8	5.4	22.0	KC 7972
510	1.5	6.3	1.6	3.2	12.0	0.8	5	3	5	19	1.6	10	3.6	4.8	5.4	23.0	KC 7973
511	1.5	8.1	1.6	3.2	12.0	0.8	5	3	5	19	1.6	10	3.6	4.8	5.4	23.0	KC 7974
512	2.5	3.6	2.3	3.9	6.5	0.8	5	2	3	15	1.6	10	4.4	5.4	6.0	20.0	KC 7975
513	2.5	4.1	2.3	3.9	7.7	0.8	5	2	3	16	1.6	10	4.4	5.4	6.0	20.0	KC 7976
514	2.5	5.1	2.3	3.9	10.0	0.8	5	2	5	18	1.6	10	4.4	5.4	6.0	22.0	KC 7977
515	2.5	6.3	2.3	3.9	12.0	0.8	5	3	5	19	1.6	10	4.4	5.4	6.0	23.0	KC 7978
516	2.5	8.1	2.3	3.9	12.0	0.8	5	3	3	19	1.6	10	4.4	5.4	6.0	23.0	KC 7979
517	4	4.1	3.1	5.5	10.0	1.2	6	3	5	20	2.0	15	6.4	7.1	8.6	31.0	KC 7980
518	4-6	4.1	3.5	5.5	10.0	1.0	6	3	3	18	2.0	15	6.4	7.1	8.6	29.0	KC 7984
519	4-6	5.1	3.5	5.5	10.0	1.0	6	3	5	20	2.0	15	6.4	7.1	8.6	31.0	KC 7985
520	4-6	4.1	3.5	5.5	8.0	1.0	6	2	5	17	2.0	15	6.4	7.1	8.6	30.0	KC 7987
521	6	5.1	3.5	5.5	8.0	1.0	6	2	5	17	2.0	15	4.4	7.1	8.6	30.0	KC 7988

PRODUCT CATALOGUE



KAYCEE
Brand that set the standards

INSULATED FERRULES

- Copper BS - 1977
- Electro Tinned finish

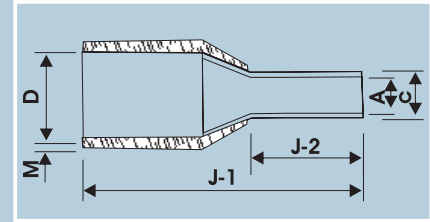

Item No.	SIZE mm ²	COLOUR	J2	A	C	D	M	J1	KAYCEE CAT. No.
522	0.5	WHITE	6	1.1	1.5	2.6	0.5	12	KCO-5-L6
523	0.5	WHITE	8	1.1	1.5	2.6	0.5	14	KCO-5-L8
524	0.5	WHITE	10	1.1	1.5	2.6	0.5	16	KCO-5-L10
525	0.75	BLUE	6	1.5	1.9	2.8	0.5	12	KCO-75-L6
526	0.75	BLUE	8	1.5	1.9	2.8	0.5	14	KCO-75-L8
527	0.75	BLUE	10	1.5	1.9	2.8	0.5	16	KCO-75-L10
528	0.75	BLUE	12	1.5	1.9	2.8	0.5	18	KCO-75-L12
529	1.0	RED	6	1.7	2.1	3.3	0.5	12	KCO-1-L6
530	1.0	RED	8	1.7	2.1	3.3	0.5	14	KCO-1-L8
531	1.0	RED	10	1.7	2.1	3.3	0.5	16	KCO-1-L10
532	1.0	RED	12	1.7	2.1	3.3	0.5	18	KCO-1-L12
533	1.5	BLACK	8	1.9	2.3	3.5	0.5	14	KCO-1.5-L8
534	1.5	BLACK	10	1.9	2.3	3.5	0.5	16	KCO-1.5-L10
535	1.5	BLACK	18	1.9	2.3	3.5	0.5	24	KCO-1.5-L18
536	2.5	GRAY	8	2.4	2.8	4.2	0.5	14	KCO-2.5-L8
537	2.5	GRAY	12	2.4	2.8	4.2	0.5	18	KCO-2.5-L12
538	2.5	GRAY	18	2.4	2.8	4.2	0.5	24	KCO-2.5-L18
539	4	ORANGE	10	2.9	3.3	4.8	0.5	16	KCO-4-L10
540	4	ORANGE	12	2.9	3.3	4.8	0.5	18	KCO-4-L12
541	4	ORANGE	18	2.9	3.3	4.8	0.5	24	KCO-4-L18
542	6	GREEN	10	3.8	4.2	6.3	0.5	18	KCO-6-L10
543	6	GREEN	12	3.8	4.2	6.3	0.5	20	KCO-6-L12
544	6	GREEN	15	3.8	4.2	6.3	0.5	23	KCO-6-L15
545	6	GREEN	18	3.8	4.2	6.3	0.5	26	KCO-6-L18
546	10	BROWN	12	4.7	5.1	7.6	0.7	22	KCO-10-L12
547	10	BROWN	15	4.7	5.1	7.6	0.7	25	KCO-10-L15
548	10	BROWN	18	4.7	5.1	7.6	0.7	28	KCO-10-L18
549	16	WHITE	12	6.0	6.4	8.8	0.7	24	KCO-16-L12
550	16	WHITE	15	6.0	6.4	8.8	0.7	27	KCO-16-L15
551	16	WHITE	18	6.0	6.4	8.8	0.7	30	KCO-16-L18

TWIN CORD END TERMINALS (NEW DEVELOPMENT)

- Copper BS - 1977
- Electro Tinned finish

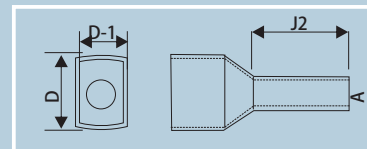

Item No.	AREA mm ²	COLOUR	J2	A	D	KAYCEE CAT. No.
552	0.5	WHITE	8.0	1.5	5.6	KCFTW-5-L8
553	0.75	GREY	8.0	1.8	6.2	KCFTW-75-L8
554	0.75	GREY	10.0	1.8	6.2	KCFTW-75-L10
555	1.0	RED	8.0	2.0	6.0	KCFTW-1-L8
556	1.0	RED	10.0	2.0	6.0	KCFTW-1-L10
557	1.5	BLACK	8.0	2.3	7.2	KCFTW-1.5-L8
558	1.5	BLACK	12.0	2.3	7.2	KCFTW-1.5-L12
559	2.5	BLUE	10.0	2.9	8.5	KCFTW-2.5-L10
560	2.5	BLUE	12.0	2.9	8.5	KCFTW-2.5-L12
561	4.0	GREY	12.0	3.8	9.2	KCFTW-4-L12
562	6.0	YELLOW	14.0	4.9	10.5	KCFTW-6-L14
563	10.0	RED	14.0	6.5	13.0	KCFTW-10-L14
564	16.0	BLUE	14.0	8.3	19.3	KCFTW-16-L14

PRODUCT CATALOGUE

ALLUMINIUM TUBLER TERMINAL ENDS FOR ALLUMINIUM CONDUCTORS

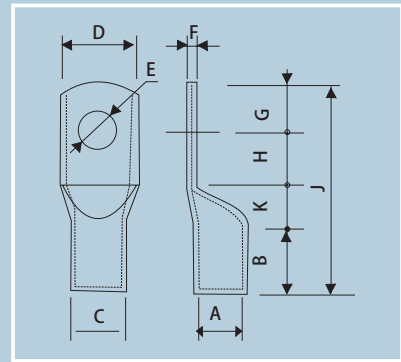

ALLUMINIUM IS : 5082

Item No.	AREA mm ²	CABLE SIZE	E	A	C	D	F	B	K	H	G	J	KAYCEE CAT. No.
565	2.5	1/1.8	3.2	2.0	5.5	6.6	3.5	7	3	4	4	18	KC-ALS-151
566	2.5	3/1.06	3.7	2.6	5.5	7.0	2.9	7	3	4	4	18	KC-ALS-309
567	4	7/0.85	4.2	2.9	5.5	7.2	2.6	7	3	4	4	18	KC-ALS-155
568	4	7/0.85	5.2	2.9	5.5	12.0	1.2	7	3	4	4	24	KC-ALS-317
569	6	7/1.06	5.2	3.5	5.5	7.5	2.0	7	4	7	6	24	KC-ALS-158
570	6	7/1.06	6.5	3.5	5.5	12.0	1.1	7	4	7	6	24	KC-ALS-313
571	10	1/3.55	4.2	3.8	6.2	8.4	2.4	7	4	9	8	28	KC-ALS-159
572	10	7/1.4	6.4	4.4	7.2	9.7	2.8	9	4	9	8	30	KC-ALS-214
573	10	7/1.4	8.2	4.4	7.2	15.0	1.8	9	4	9	8	30	KC-ALS-215
574	16	7/1.7	6.4	5.4	8.3	11.4	2.9	13	4	11	9	37	KC-ALS-252
575	16	7/1.7	8.2	5.4	8.3	11.4	2.9	13	4	11	9	37	KC-ALS-216
576	16	7/1.7	10.2	5.4	8.3	18.0	1.8	13	4	11	9	37	KC-ALS-217
577	25	7/2.24	6.4	7.0	9.7	13.7	2.7	16	7	12	9	44	KC-ALS-253
578	25	7/2.24	8.2	7.0	9.7	13.7	2.7	16	7	12	9	44	KC-ALS-218
579	25	7/2.24	10.2	7.0	9.7	20.0	1.7	16	7	11	10	44	KC-ALS-219
580	25	7/2.24	12.7	7.0	9.7	20.0	1.7	16	7	11	10	44	KC-ALS-220
581	35	7/2.5	6.4	8.0	10.8	15.14	2.8	18	7	11	11	47	KC-ALS-254
582	35	7/2.5	8.2	8.0	10.8	15.14	2.8	18	7	11	11	47	KC-ALS-221
583	35	7/2.5	10.2	8.0	10.8	20.0	2.1	18	7	11	11	47	KC-ALS-222
584	50	19/1.8	8.2	9.3	13	18.3	3.7	22	8	13	11	54	KC-ALS-255
585	50	19/1.8	10.2	9.3	13	23.0	2.8	22	8	13	11	54	KC-ALS-312
586	50	19/1.8	12.7	9.3	13	23.0	2.8	22	8	12	12	54	KC-ALS-224
587	70	19/2.24	8.2	17.6	16	22.6	4.4	26	8	13	13	60	KC-ALS-256
588	70	19/2.24	10.2	11.6	16	22.6	4.4	26	8	13	13	60	KC-ALS-225
589	70	19/2.24	12.7	11.6	16	22.6	4.4	26	8	13	13	60	KC-ALS-226
590	95	19/2.5	10.2	12.9	17.1	24.5	4.2	28	8	14	14	64	KC-ALS-227
591	95	19/2.5	12.7	12.9	17.1	24.5	4.2	28	8	14	14	64	KC-ALS-228
592	95	19/2.5	16.2	12.9	17.1	24.5	4.2	28	8	14	14	64	KC-ALS-229
593	120	37/2.06	10.2	15.0	19.0	28.2	4.6	32	11	15	15	73	KC-ALS-257
594	120	37/2.06	12.7	15.0	19.0	28.2	4.6	32	11	15	15	73	KC-ALS-230
595	120	37/2.06	16.2	15.0	19.0	28.2	4.6	32	11	15	15	73	KC-ALS-231
596	150	37/2.24	10.2	16.5	21.5	30.9	5.0	34	11	17	17	79	KC-ALS-258
597	150	37/2.24	12.7	16.5	21.5	30.9	5.0	34	11	17	17	79	KC-ALS-232
598	150	37/2.24	16.2	16.5	21.5	30.9	5.0	34	11	17	17	79	KC-ALS-233
599	185	37/2.5	10.2	18.6	24.0	34.6	5.5	36	12	18	18	84	KC-ALS-311
600	185	37/2.5	12.7	18.6	24.0	34.6	5.5	36	12	18	18	84	KC-ALS-234
601	185	37/2.5	16.2	18.6	24.0	34.6	5.5	36	12	18	18	84	KC-ALS-235
602	225	37/2.8	12.7	21	27	39.0	6.0	40	14	20	20	94	KC-ALS-320
603	240	37/3.0	12.7	22	28	40.0	6.0	44	14	22	22	102	KC-ALS-236
604	240	37/3.0	16.2	22	28	40.0	6.0	44	14	22	22	102	KC-ALS-237
605	300	61/2.5	16.2	24	31	45.7	7.0	47	14	27	27	115	KC-ALS-300
606	300	61/2.5	20.3	24	31	45.7	7.0	47	14	27	27	115	KC-ALS-259
607	400	61/3.0	20.3	28	36	51.0	8.0	56	13	31	30	130	KC-ALS-260
608	500	91/2.65	20.3	31	41	58.7	10.0	60	15	33	32	140	KC-ALS-296
609	625	91/3.0	20.3	36	46	66.6	10.0	69	16	35	34	154	KC-ALS-261
610	800	91/3.35	---	39	51	73.3	12.0	77	25	39	39	180	KC-ALS-318
611	1000	91/3.75	---	43.5	57	81.9	13.5	100	30	45	45	220	KC-ALS-319

ALLUMINIUM TUBULAR IN - LINE CONNECTORS FOR ALLUMINIUM CONDUCTORS

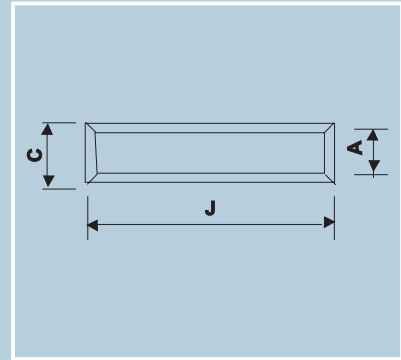

ALLUMINIUM IS : 5082

Item No.	AREA mm ²	CABLE SIZE	A	C	J	KAYCEE CAT. No.
612	2.5	1/1.8	2.0	5.5	16	KC-ALS-145
613	2.5	3/1.06	2.6	5.5	16	KC-ALS-6
614	4	7/0.85	2.9	5.5	16	KC-ALS-5
615	6	7/1.12	3.5	5.5	16	KC-ALS-13
616	10	1/3.55	3.8	6.2	20	KC-ALS-146
617	10	7/1.4	4.4	7.4	20	KC-ALS-14
618	16	7/1.7	5.4	8.3	26	KC-ALS-4
619	25	7/2.24	7.0	9.7	35	KC-ALS-3
620	35	7/2.5	8.0	10.8	40	KC-ALS-2
621	50	19/1.8	9.3	13.0	45	KC-ALS-12
622	70	19/2.24	11.6	16.0	55	KC-ALS-1
623	95	19/2.5	12.9	17.1	60	KC-ALS-15
624	120	37/2.06	15.0	19.0	65	KC-ALS-9
625	150	37/2.24	16.5	21.2	70	KC-ALS-10
626	185	37/2.5	18.5	24.0	75	KC-ALS-11
627	225	37/2.8	21.0	27.0	85	KC-ALS-147
628	240	37/3.0	22.0	28.6	90	KC-ALS-16
629	300	61/2.5	24.0	31.0	100	KC-ALS-17
630	400	61/3.0	28.0	36.0	115	KC-ALS-18
631	500	91/2.65	31.0	41.0	125	KC-ALS-19
632	625	91/3.0	36.0	46.0	140	KC-ALS-20
633	800	91/3.35	39.0	51.0	160	KC-ALS-148
634	1000	91/3.75	43.5	57.0	210	KC-ALS-149



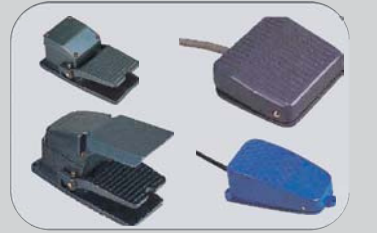
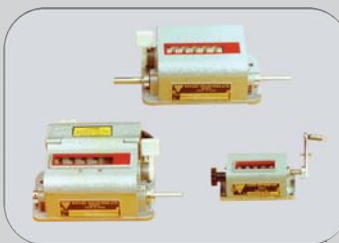

KAYCEE INDUSTRIES LIMITED



32, Ramjibhai Kamani Road, Ballard Estate, Mumbai - 400 001
Tel.: 91-22-22613521 / 22 / 23 Fax: 91-22-22616106
Website: www.kayceeindustries.com
Email: kaycee_ho@cms.com, kayceeindltd@vsnl.com

Offices at:

- Bangalore :** # 9/2, First Floor, Dhondusa Complex, Residency Road, Bangalore - 560 025.
Mobile : 9342853324
- Chennai :** CMS Tower, 42, Cathedral Road, Chennai - 600 086. Mobile: 9381201556
- Kolkatta :** 10/D/2, Hochi Minh Sarani, 1st Floor, Kolkatta - 700 071.
Mobile : 9339200968
- New Delhi :** 35 - A, Rear Building, Near CTC Plaza, Opp. Maharani Bagh, Ring Road,
Kilokari, New Delhi - 110 014. Mobile : 9312004687
- Indore :** Mobile : 9300751464

REPUTED CUSTOMERS: n ABB n Crompton Greaves n L&T n Siemens n C&S n BHEL n GE Power n NTPC n ICF n RCF n Areva T&D n Schneider n HMT n Bharti Airtel n Reliance n Jyoti Ltd. n Mega Win n BSES n Hindustan Motors n Indian Railways